

---

**PRODUCT SPECIFICATION  
FOR LCD MODULE**  
(产品规格书)

**Reversion (版本) : 1.0**

**Module No. (模组型号) : HYS-056BT3S5P001**

**Customer Name: (客户名) : \_\_\_\_\_**

**Project Name: (客户项目名) : \_\_\_\_\_**

**CUSTOMER APPROVED (客户确认) :**

结构部	电子部	品质部	项目部

**Please sign back after confirmed. (确认后请签回)**

**SHEN ZHEN KELAI ELECTRONICS CO., LTD**

QA Dept. (品质)	Tech. Dept. (工程)	Sale Dept. (业务)



---

## CONTENTS 目录

1. GENERAL INFORMATION 主要特征描述
2. ELECTRICAL CHARACTERISTICS 电气参数
  - 2.1 LCM Electrical Characteristics 模组电气参数
3. EXTERNAL DIMENSIONS AND INTERFACE DESCRIPTION 外形接口定义
  - 3.1 External Dimensions 外形尺寸
  - 3.2 LCM interface description LCM 接口功能描述
  - 3.3 TP interface description TP 接口功能描述
  - 3.4 Power on/off sequence 上下电时序描述
  - 3.5 RGB Interface Definition 屏参描述
4. ELECTRO-OPTICAL CHARACTERISTICS 光电参数
  - 4.1 LCM ELECTRO\_Optical Characteristics LCM 光电参数
5. RELIABILITY TEST CONDITIONS 可靠性试验条件

## 1. GENERAL INFORMATION 主要特征描述

Item of general information 项目	Contents 内容	Unit 单位
LCD Type 液晶显示类型	TFT/TRANSMISSIVE	/
Recommended Viewing Direction 模块推荐使用方向	ALL	O' Clock
Module area (W×H×T) 模块外围尺寸(宽×高×厚)	126.5(W)*100(L)*5.9(H)	mm
Active area (W×H) 有效区域 (宽×高)	115.2(W)* 86.40(L)	mm
Number of Dots 点阵	640(RGB)×480	/
Pixel pitch (W×H) 像素大小(宽×高)	180(H)×180(V)	um
Driver IC 驱动IC	JD9168S	/
Interface Type 接口类型	RGB	/
Colors 色彩	16.7M	/
Backlight Type 背光类型	LED	/

## 2. Electrical Characteristics 电气参数

### 2.1 LCM Electrical Characteristics 模组电气参数

#### 2.1.1. ABSOLUTE MAXIMUM RATINGS 极限参数

Parameter of absolute maximum ratings 参数	Symbol 符号	Min 最小值	Max 最大值	Unit 单位
Operating temperature 操作温度	T <sub>op</sub>	-20	70	°C
Storage temperature 储存温度	T <sub>st</sub>	-30	80	°C
Humidity 湿度	RH	-	90%(Max60 °C)	RH

#### 2.1.2. ELECTRICAL CHARACTERISTICS 模块电气特性

Parameter of DC characteristics 参数	Symbol 符号	Min 最小值	Typ 典型值	Max 最大值	Unit 单位
Supply Voltage	VDD	2.8	3.0	3.3	V
	-	-	-	-	
	-	-	-	-	
Input Current 输入电流	I <sub>vdd</sub>	-	60		mA
Input voltage 'H' level 输入高电平	V <sub>IH</sub>	0.7V <sub>CC</sub>	-	V <sub>CC</sub>	V
Input voltage 'L' level 输入低电平	V <sub>IL</sub>	V <sub>SSI</sub>	-	0.3V <sub>CC</sub>	V

### 2.1.3. Backlight Characteristics 背光电气特性

Item of backlight characteristics 项目	Symbol	Min.	Typ.	Max.	Unit	Condition
Forward voltage 正向电压	$V_f$	8.1	9.0	9.9	V	$I_f=100\text{mA}$
Number of LED LED数量	-	-	15	-	Piece	-
Connection mode 连接类型	3S5P	-		-	-	-

Using condition: constant current driving method  $I_f=100\text{mA}(\pm 10\%)$ .

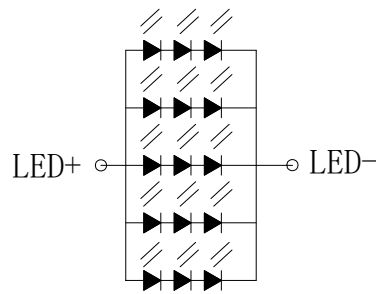

Backlight LED Circuit  
( $I_f=100\text{mA}$ ,  $V_f=9.0\text{V}-9.9\text{V}$ )



### 3.2 LCM interface description LCM接口

Pin No.	Symbol	I/O	Function
1-2	VLED+	P	LED back light(Anode)
3-4	VLED-	P	LED back light(Cathode)
5	GND	P	Ground.
6	VCOM ( NC )	I	No connection
7	VCC	P	Digital Power Supply Voltage.
8	MODE(NC)	I	No connection
9	DE	I	Data enable pin.
10	VS	I	Frame sync signal.
11	HS	I	Line sync signal.
12-19	B7-B0	I	Blue data bus.
20-27	G7-G0	I	Green data bus .
28-35	R7-R0	I	Red data bus.
36	GND	P	Ground.
37	DCLK	I	Data clock.
38	GND	P	Ground.
39	L/R	I	Left/right scan direction on panel module.
40	U/D	I	Up/down scan direction on panel module.
41	VGH (NC)		No connection.
42	VHL(NC)		No connection.
43	AVDD(NC)		No connection.
44	RESET	I	Global reset.
45	POL(NC)		No connection.
46	VCOM(NC)		No connection.
47	SCL(NC)	I	Serial interface clock.Fix to VDDI or VSS when not in use.
48	SDA(NC)	I	SPI interface data input /output pin. Fix to VDDI level when not in use.
49	CS(NC)	I	Chip select input pin ( "Low" enable).
50	STBYB(NC)	P	STBYB

注：此产品只支持DE+HV及HV模式，不支持单独DE模式

### 3.4 Power on/off sequence.

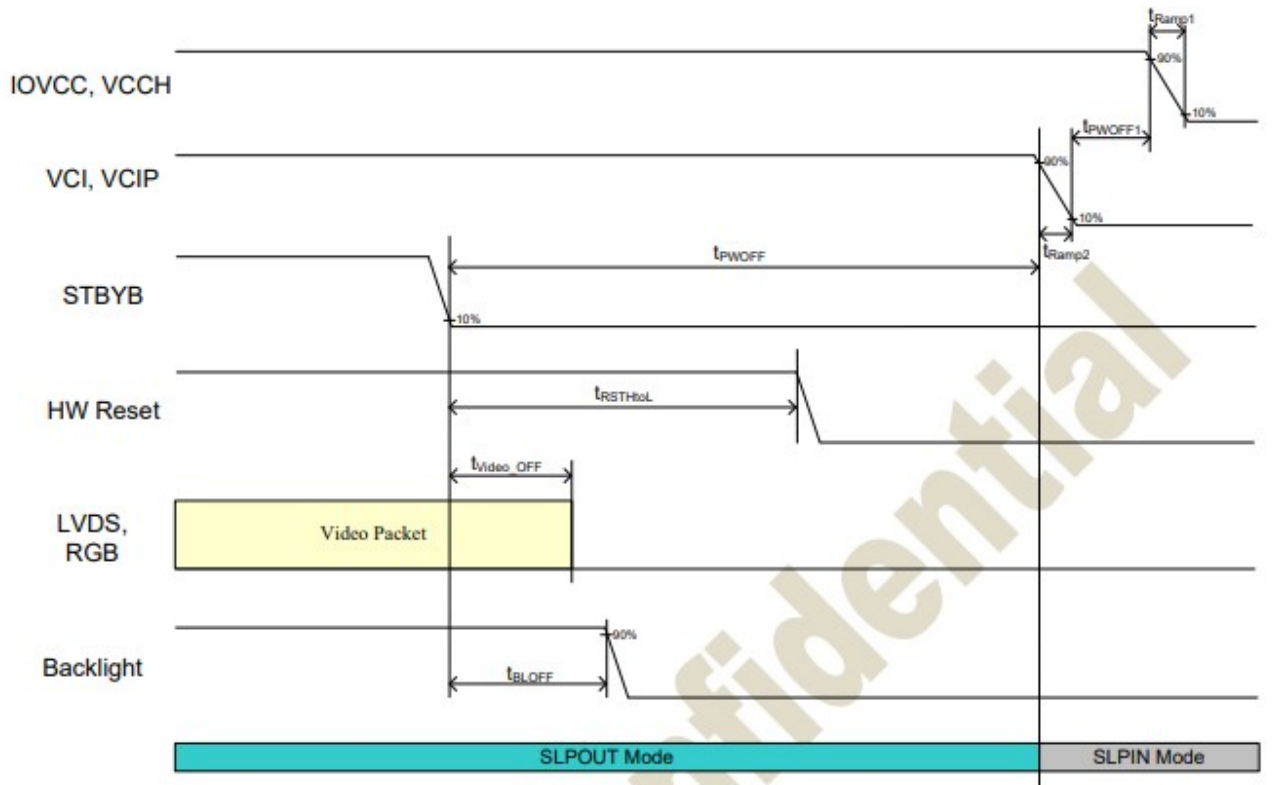
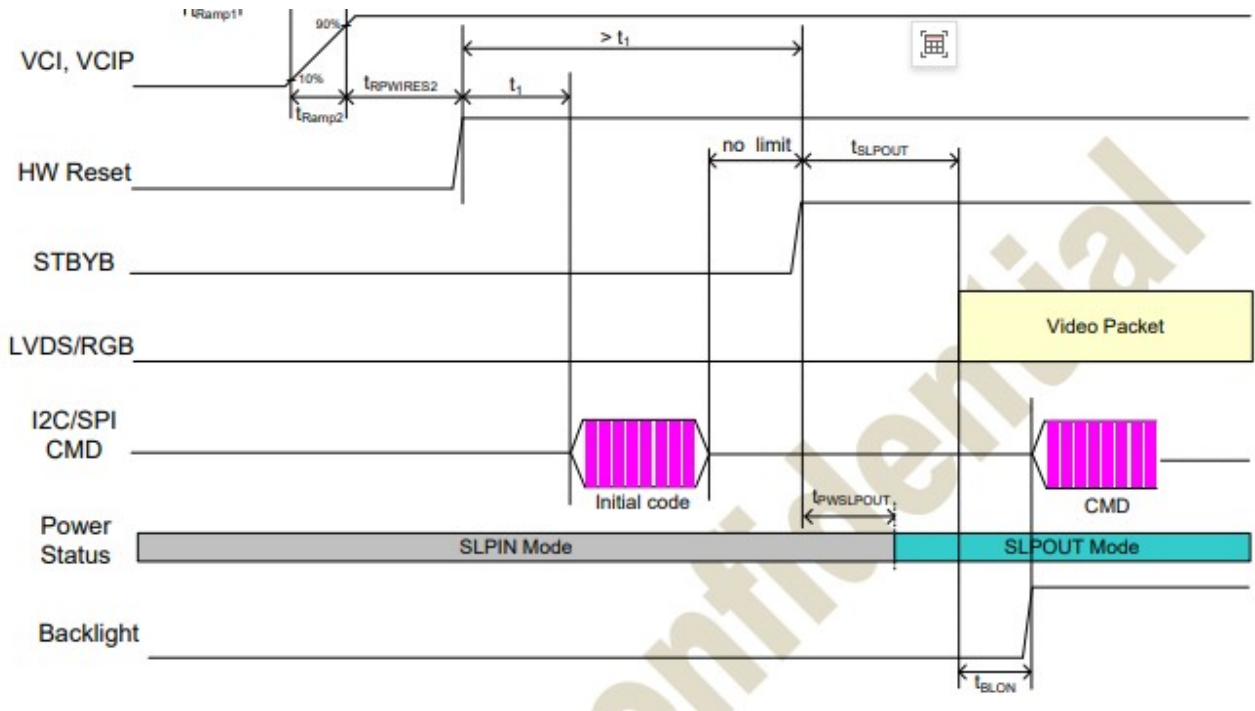



### 3.5. RGB Interface Definition

#### Horizontal Timing

Parameter	Symbol	Spec.			Unit
		Min.	Typ.	Max.	
DCLK Frequency	fclk	-	21	-	MHz
Horizontal Display Area	thd	640			DCLK
HS Period	th		-	-	DCLK
HS Pulse Width	thpw	-	4	-	DCLK
HS Back Porch	thbp	-	10	-	DCLK
HS Front Porch	thfp	-	10	-	DCLK

#### Horizontal Timings

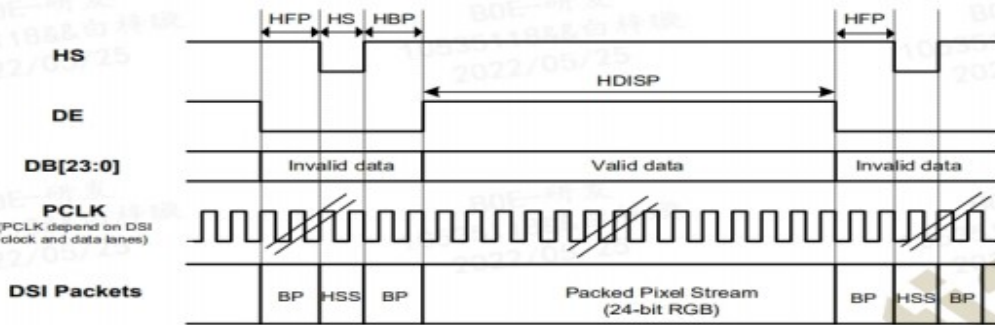

#### Vertical Timing

Parameter	Symbol	Spec.			Unit
		Min.	Typ.	Max.	
Vertical Display Area	tvd	480			TH
VS Period	tv	-	-	-	TH
VS Pulse Width	tvpw	-2	2	-	TH
VS Back Porch	tvbp	-	22		TH
VS Front Porch	tvfp	-	18	-	TH

#### Vertical Timings

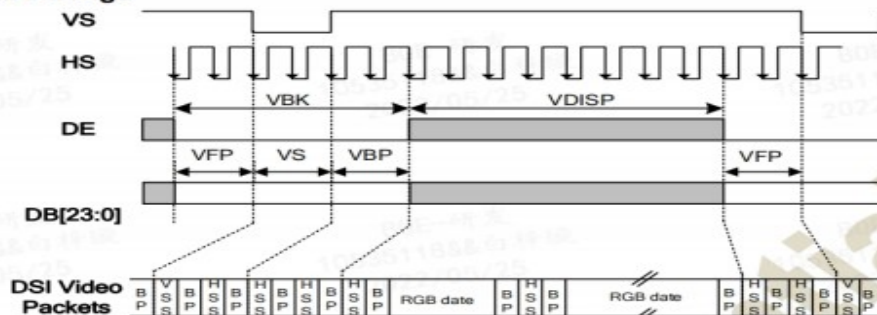

## 4. ELECTRO-OPTICAL CHARACTERISTICS 光电参数

### 4.1 LCM ELECTRO\_Optical Characteristics LCM光电参数

Item of electro-optical characteristics 项目	Symbol 符号	Condition 条件	Min 最小值	Typ 典型值	Max 最大值	Unit 单位	Remark 注释
Contrast ratio 对比度	CR	$\theta = 0^\circ$ $\psi = 0^\circ$ $I_f = 20\text{mA}$ /LED	1000	1200	-	-	Note 1
Surface Luminance 表面亮度	Lv		350	400	-	Cd/m <sup>2</sup>	Note 2
Luminance uniformity 均匀度	$\delta$ (WHITE)		75	80	-	%	Note 3
Response time 响应时间	Tr+Tf		-	30	35	ms	Note 4
Viewing angle range 视角范围	$\theta$ (CR $\geq 10$ )	60' clock	75	80	-	degree	Note 5
		120' clock	75	80	-		
		30' clock	75	80	-		
		90' clock	75	80	-		
Module Chromaticity CIE (x, y) 色坐标	White	x	0.245	0.275	0.305	-	Note6
		y	0.260	0.290	0.320		
NTSC Ratio 色域	S	-	-	60	-	%	Note7

Note1. Contrast Ratio (CR) is defined mathematically by the following formula. For more information see FIG 1.:

$$\text{Ratio} = \frac{\text{Average Surface Luminance with all white pixels (P1, P2, P3, P4, P5, P6, P7, P8, P9)}}{\text{Average Surface Luminance with all black pixels (P1, P2, P3, P4, P5, P6, P7, P8, P9)}}$$

备注1. 对比度是由以下公式计算所得。详见FIG 1.。

$$\text{对比度} = \frac{\text{显示白色画面时平均表面亮度(P1, P2, P3, P4, P5, P6, P7, P8, P9)}}{\text{显示黑色画面时平均表面亮度(P1, P2, P3, P4, P5, P6, P7, P8, P9)}}$$

Note2. Surface brightness is the center brightness value of the test when displaying a white screen. For more information see FIG 1.

$$L_v = \text{Surface Luminance with center pixels (P5)}$$

备注2. 表面亮度是在显示白色画面时，测试的中心亮度值，详见FIG 1.。

$$L_v = \text{中心点表面亮度(P5)}$$

Note3. The uniformity in surface luminance ( $\delta$  WHITE) is determined by measuring luminance at each test

position 1 through 9, and then dividing the maximum luminance of 9 points luminance by minimum luminance of 9 points luminance. For more information see FIG 1.

$$\delta \text{ WHITE} = \frac{\text{Minimum Surface Luminance with all white pixels (P1, P2,P3,P4,P5,P6,P7,P8,P9)}}{\text{Maximum Surface Luminance with all white pixels (P1, P2,P3,P4,P5,P6,P7,P8,P9)}}$$

备注3. 均匀度是在显示白色画面时，测试P1到P9的亮度，然后再用5个点亮度的最小值除以最大值。详见FIG 1.。

$$\text{均匀度} = \frac{\text{表面亮度最小值(P1, P2, P 3,P4, P5,P6,P7,P8,P9)}}{\text{表面亮度最大值(P1, P2, P 3,P4, P5,P6,P7,P8,P9)}}$$

Note4. Response time is the time required for the display to transition from White to black(Rise Time, Tr) and from black to white(Decay Time, Tf). For additional information see FIG 2..

备注4. 响应时间是Tr(上升时间)与Tf(下降时间)的和; Tr 指显示黑色画面转为显示白色画面需要时间, Tf 指显示白色画面转为显示黑色画面需要时间。详见FIG 2.。

Note5. Viewing angle is the angle at which the contrast ratio is greater than 2. For TFT module the contrast ratio is greater than 10. The angles are determined for the horizontal or x axis and the vertical or y axis with respect to the z axis which is normal to the LCD surface. For more information see FIG 3.

备注5. 视角指对比度大于等于2时的可视范围，对TFT 屏，则是对比度大于等于10 的可视范围。视角由横轴（x轴），竖轴（y轴）同Z轴(垂直于LCD 表面)之间的夹角来定义。详见FIG 3.

Note6. CIE (x, y) chromaticity ,The x,y value is determined by screen active area position 5. For more information see FIG 1.

备注6. CIE(x,y) 色坐标测试点为显示屏中心点P5。详见FIG 1.

Note7: NTSC ratio: For more information see FIG 4.

$$\text{NTSC ratio} = \frac{\text{Area of RGB triangle}}{\text{Area of NTSC triangle}}$$

备注7. 色域比： 详见FIG 4

$$\text{NTSC ratio} = \frac{\text{RGB三色三角形面积}}{\text{标准NTSC三角形面积}}$$

Note8. For Viewing angle and response time testing, the testing data is base on Autronic-Melchers's ConoScope. Series Instruments. For contrast ratio, Surface Luminance, Luminance uniformity and CIE, the testing data is base on BM-7 photo detector.

备注8. 视角和响应时间， 测试数据基于Autronic-Melchers's ConoScope. 系列。而对比度，表面亮度，均匀度，CIE 坐标，测试数据基于BM-7 photo detector.

Note9. For TFT transmissive module, Gray scale reverse occurs in the direction of panel viewing angle

备注9. TFT 全透产品,在视角方向会发生灰度反转

FIG. 1. Measuring method for Contrast ratio, surface luminance, Luminance uniformity, CIE (x, y) chromaticity对比度，表面亮度，均匀度，CIE坐标测试方法

A :H/6 mm

B : V/6 mm

Active Area

spot size  $\phi=5\text{mm}$ , 500mm distance from the surface to detector lens

measurement instrument is luminance meter BM-7

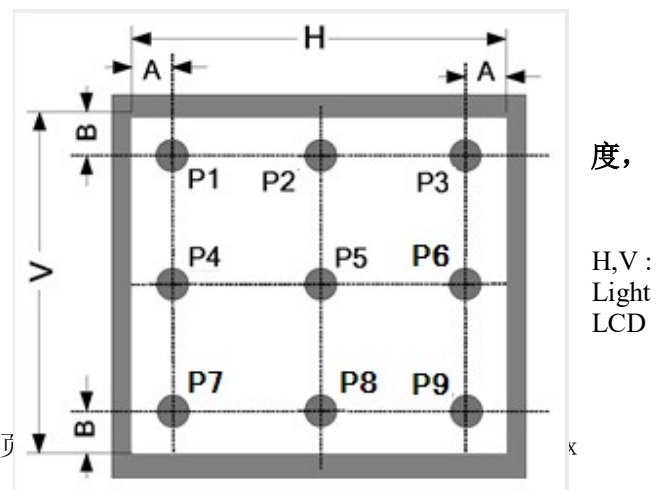

FIG. 2. The definition of Response Time 响应时间定义

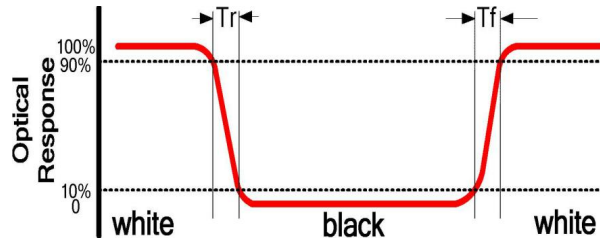

FIG.3. The definition of viewing angle 视角定义

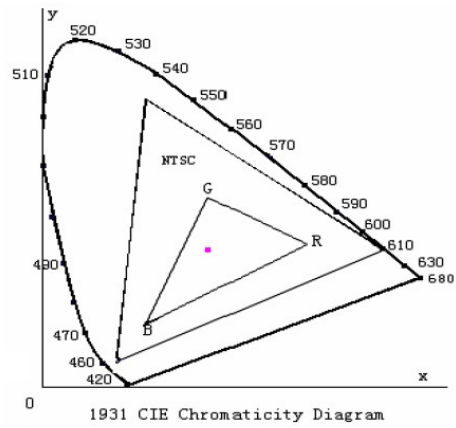
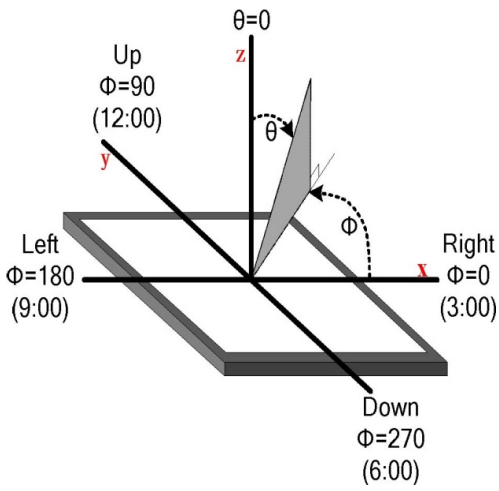

Fig.4. 1931 CIE chromaticity diagram

## 5. RELIABILITY TEST CONDITIONS 可靠性试验条件

No. 序号	Test Item 试验项目	Test Condition 试验条件	Inspection after test 判断标准
1	High Temperature Storage 高温存放	80±2℃/96 hours	Inspection after 2~4hours storage at room temperature, the sample shall be free from defects: 试验结束后, 已测试的LCD 样品必须在室内正常温湿度环境下放置2~4 个小时以上才能进行功能和外观检查, 样品不允许有以下缺陷: 1.Air bubble in the LCD; 模块中有气泡; 2.Sealleak; 封口松脱; 3.Non-display; 不显示; 4.missing segments; 漏笔 5.Glass crack; 玻璃破碎; 6.Current Idd is twice higher than initial value. 电流Idd 大于初时值的2 倍 7, the surface shall be free from damage..表面无损伤. 8. The electrical characteristics requirements shall be satisfied. 需要满足模块电气性能。
2	Low Temperature Storage 低温存放	-30±2℃/96 hours	
3	High Temperature Operating 高温操作	70±2℃/96 hours	
4	Low Temperature Operating 低温操作	-20±2℃/48 hours	
5	Temperature Cycle 冷热循环	-10±2℃(30min.)~60(30min.)±2℃×48 cycles	
6	High temperature and high humidity 高温高湿	60℃±5℃×90%RH/48 hours	
7	Vibration Test 振荡试验	Frequency: 10Hz~55Hz~10Hz Amplitude: 1.5mm, X, Y, Z direction for total 0.5hours (Packing condition)	
8	Dropping test 跌落试验	Drop to the ground from 1.0m height, one time, every side of carton. (Packing condition)	
9	ESD test 静电试验	R: 330Ω C: 150pF , 10time Air discharge: ±6KV Contact discharge: ±4KV	
Remark: 注意: 1. The test samples should be applied to only one test item. 每个被测试的模块只能用于其中的一个测试项目。 2. Sample size for each test item is 5~10pcs. 每个测试项目的样品数量为5~10 片。 3. For Damp Proof Test, Pure water(Resistance>10MΩ) should be used. 对于防潮试验, 试验箱的用水必须是电阻大于10M 欧姆的纯水。 4. In case of malfunction defect caused by ESD damage, if it would be recovered to normal state after resetting, it would be judged as a good part. 如果由静电引起产品故障, 当放置一段时间后能够恢复正常, 则不视为产品缺陷。 5. EL evaluation should be excepted from reliability test with humidity and temperature: Some defects such as black spot/blemish can happen by natural chemical reaction with humidity and Fluorescence EL has. 带EL片的可靠性测试在高温高湿条件下, 荧光粉会发生自然化学反应而产生黑点或瑕疵, 因此不在高温高湿条件测试范围内。 6. Failure Judgment Criterion: Basic Specification, Electrical Characteristic, Mechanical Characteristic, Optical Characteristic. 故障判断标准: 基本规格, 电气特性, 机械特性, 光电特性			